

TECHNO Dual-plate, Metal-hinged Wafer-style Check Valves

ASME Class 125 and 150



TECHNO Dual-Plate, Metal-Hinged, Wafer-Style Check Valves

DESIGN FEATURES

BODY

TECHNO™ brand's body design offers the following features:

- Compact wafer-style, one-piece design
- Center post fully supports the internal assembly without external pins or plugs
- No leakage to atmosphere is ensured due to TECHNO's standard design, which eliminates through holes and pipe plugs in the body
- Maximum flow area reduces pressure loss
- Reduces installation space and time

VALVE PLATES

The dual-plate design produces increased strength with reduced opening and closing time.

CLAMP PLATES

Clamp plates offer additional strength to valve plates and allow seals to be changed easily.

SEALS

Specially designed flat, full-contact seals maintain positive shutoff at low working pressures. Unlike most other valves, these seals are replaced easily in the field.

SPRINGS

Torsion springs assist valve plate closure, preventing flow reversal. Consistent valve response ensures against slamming and water hammer.

SHAFT

The shaft features heavy-duty, corrosion-resistant construction.

SHAFT SUPPORTS

Shaft supports act as stops to prevent over-travel of valve plates. They are corrosion resistant with large shaft-bearing surfaces and are easily removable for internal assembly, maintenance or change.

THRUST WASHERS

Thrust washers reduce friction and wear of valve plate hinges.

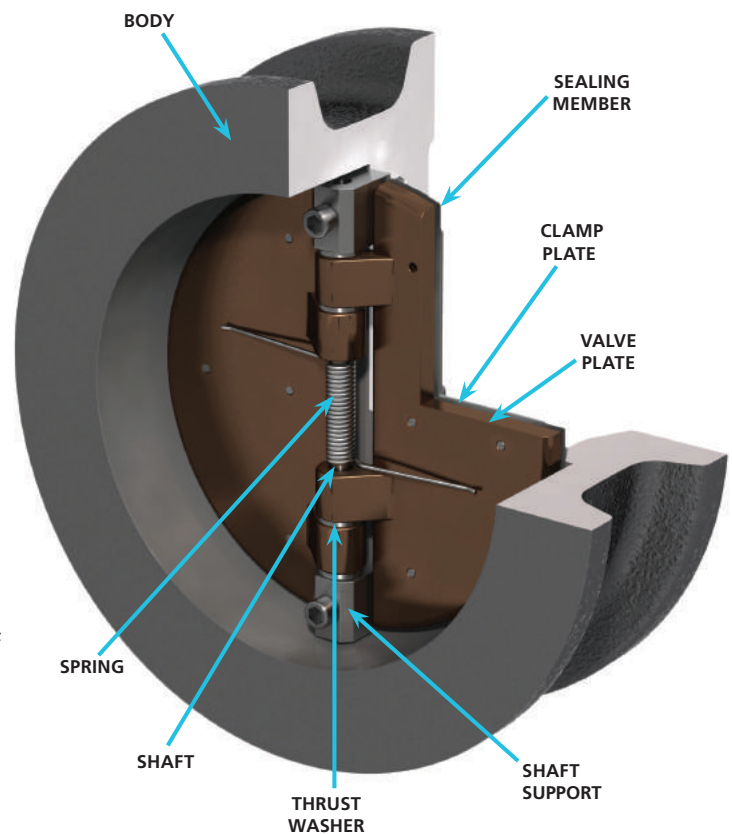

Standard Models and Materials of Construction

Style	Body	Valve Plates	Seals	Springs	Trim*	ASME Class
5050	Cast Iron	Bronze	Buna-N	316 SS	316 SS	125
5051	Carbon Steel	Carbon Steel**	Buna-N	316 SS	316 SS	150
5051-316	316 SS	316 SS	Buna-N	316 SS	316 SS	150
5053	Carbon Steel	Carbon Steel**	Metal-Metal	316 SS	316 SS	300
5053-316	316 SS	316 SS	Metal-Metal	316 SS	316 SS	300
5056	Carbon Steel	Carbon Steel**	Metal-Metal	316 SS	316 SS	600
5056-316	316 SS	316 SS	Metal-Metal	316 SS	316 SS	600

* Trim items include: shaft, shaft supports, clamp plates, and fasteners. Teflon® or stainless steel thrust washers are standard.

** 316 stainless steel is standard on 2" to 6" check valves.

Optional Materials Selection

Spring Data	
Materials	Temperature Range **
INCONEL®	750° F
INCONEL X	1000° F

Seal Data	
Materials	Temperature Range **
Buna-N	-60° F to 225° F
EPDM	-40° F to 300° F
Viton®/FKM	-20° F to 400° F
Teflon	-20° F to 450° F
Silicone	-90° F to 500° F
FDA-Approved	-40° F to 225° F
Metal-to-Metal*	-400° F to 1000° F

**This temperature is for general guidance.

The figures may vary with application and body/internal materials.

*316 stainless steel thrust washers are standard with metal-to-metal seal option.

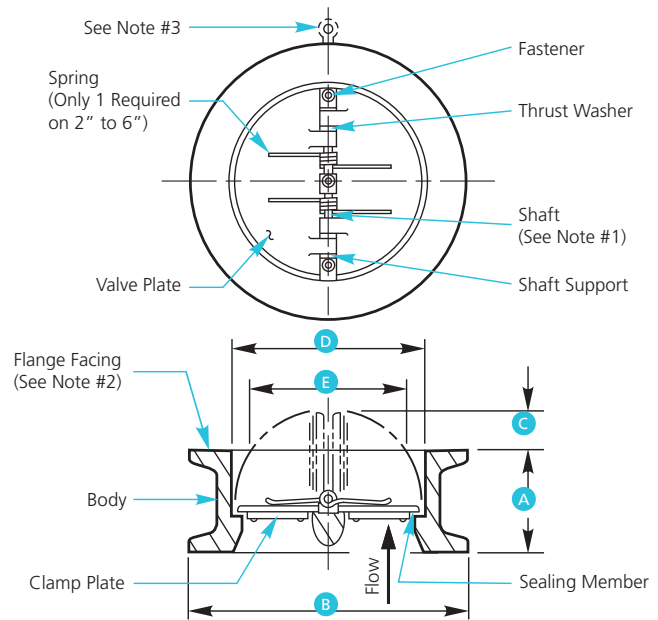

Note 1: Shaft must be in vertical position for horizontal flow application.

Note 2: Plain face (non-serrated) for style 5050 only.

Raised faces for all other carbon and stainless steel sizes.

Note 3: Lifting lug feature optional on 6" to 36" sizes.

General Dimensions (all dimensions in inches)

Valve Size	ASME Class	A	B	C	D	E†
2"	125	2-1/8	4-1/8	-	2-1/8	-
	150	2-3/8	4-1/8	-	2-1/4	-
2-1/2"	125	2-1/8	4-7/8	1/8	2-5/8	1-3/8
	150	2-5/8	4-7/8	-	2-3/4	-
3"	125	2-1/4	5-3/8	3/8	3-1/8	2-1/8
	150	2-7/8	5-3/8	-	3-3/16	-
4"	125	2-1/2	6-7/8	7/8	4-1/8	3-1/2
	150	2-7/8	6-7/8	1/2	4-3/16	2-7/8
5"	125	2-3/4	7-3/4	1-1/4	5-1/8	4-1/2
	150	3-3/8	7-3/4	5/8	5-3/16	3-1/2
6"	125	3	8-3/4	1-7/8	6-1/8	5-3/4
	150	3-7/8	8-3/4	1	6-3/16	4-3/4
8"	125	3-3/4	11	2-3/4	8-1/4	7-7/8
	150	5	11	1-1/2	8-5/16	6-5/8
10"	125	4-1/4	13-3/8	3-7/8	10-1/8	9-7/8
	150	5-3/4	13-3/8	2-3/8	10-3/16	8-3/4

Valve Size	ASME Class	A	B	C	D	E†
12"	125	5-5/8	16-1/8	4	12-1/8	11-1/2
	150	7-1/8	16-1/8	2-1/2	12-3/16	10
14"	125	7-1/4	17-3/4	3-1/2	14-1/8	12-1/2
	150	7-1/4	17-3/4	3	14-1/8	12
16"	125	7-1/2	20-1/4	4-3/4	16-1/8	15
	150	7-1/2	20-1/4	4-1/8	16-1/8	14-3/8
18"	125	8	21-5/8	5-5/8	18-1/8	16-7/8
	150	8	21-5/8	5	18-1/8	16-1/4
20"	125	8-3/8	23-7/8	6-1/2	20-1/8	18-13/16
	150	8-5/8	23-7/8	5-1/2	20-1/8	18-1/8
24"	125	8-3/4	28-1/4	8-1/4	24-1/8	22-5/8
	150	8-3/4	28-1/4	8	24-1/8	22-5/8
30"	125	12	34-3/4	10-1/4	30-1/8	28-5/8
	150	12	34-3/4	9-1/4	30-1/8	27
36"	125	14-1/2	41-1/4	12-1/2	36-9/16	34
	150	14-1/2	41-1/4	11	36-1/8	33

†Minimum bore diameter of companion flanges.

BODY MATERIALS	VALVE PLATE MATERIALS
<ul style="list-style-type: none"> • Cast Iron – ASTM A126 Grade B • Carbon Steel – ASTM A216 Grade WCB • 316 Stainless Steel – ASTM A351 Grade CF8M 	<ul style="list-style-type: none"> • Bronze – ASTM B62 Alloy C836 • Carbon Steel – ASTM A216 Grade WCB • 316 Stainless Steel – ASTM A351 Grade CF8M
TRIM MATERIALS	SPRING MATERIALS
<ul style="list-style-type: none"> • 316 Stainless Steel – For shaft, shaft supports, clamp plates and threaded fasteners 	<ul style="list-style-type: none"> • 316 Stainless Steel – ASTM A313; Standard in all valves; Maximum temperature is 500° F • Inconel – ASTM B166; Optional for temperatures to 750° F • Inconel X – ASTM B166; Optional for temperatures above 750° F

ASME PRESSURE – TEMPERATURE RATING Maximum Non-Shock Pressure – psi

Temp ° F	Class 125			Temp ° F	Class 150	
	Cast Iron				Carbon Steel	316 Stainless Steel
	2" - 12"	14" - 24"	30" - 36"			
150° F	200	150	150	100° F	285	275
200° F	190	135	115	200° F	260	240
225° F	180	130	100	300° F	230	215
250° F	175	125	85	400° F	200	195
275° F	170	120	65	500° F	170	170
300° F	165	110	50	600° F	140	140
325° F	155	105	-	700° F	110	110
350° F	150	100	-	800° F	80	80
400° F	140	-	-	900° F	50	50
450° F	125	-	-	1000° F	20	20
Hydrostatic Test – psi	350	265	265	Hydrostatic Test – psi	450	425

CAUTION: Maximum valve temperature rating often is limited by seal and spring materials.

INDUSTRY STANDARDS

TECHNO dual-plate, metal-hinged, wafer-style check valves are designed, rated and manufactured in accordance with the following industry standards:

- ANSI B16.1, ANSI B16.34 and ANSI B16.5
- ASME Sections II and VIII
- API 594, except face-to-face dimensions of 2-1/2" to 12" cast iron valve (Style 5050)

If required by your job needs, we can provide the requisite documentation to verify our valves meet the stringent design and material criteria set forth in the above standards. Also, we can perform and document the hydrostatic and leak tests required by API 598, MSS-SP-61 or other such guides.

PRESSURE DROP CHARTS FOR WATER SERVICE
(Based on Horizontal Flow Application)

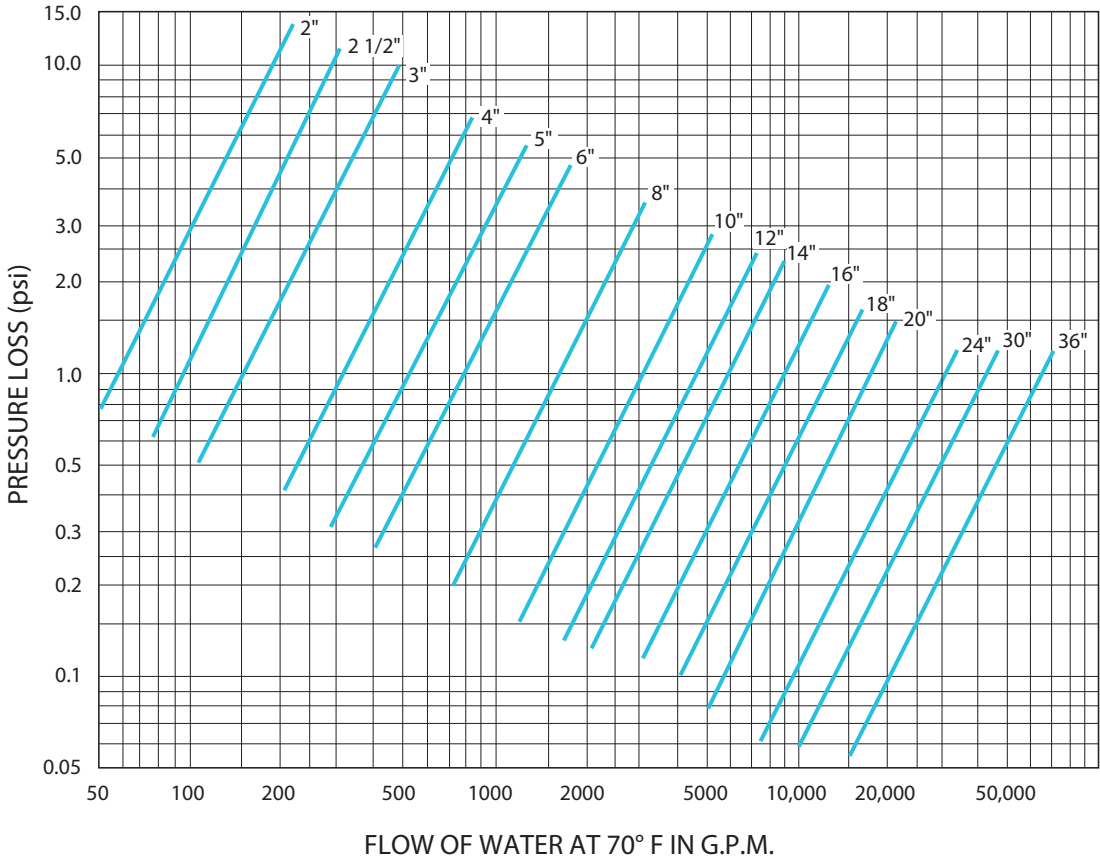

FLOW COEFFICIENTS

Valve Size	C _v *
2"	58
2-1/2"	92
3"	160
4"	320
5"	525
6"	800
8"	1700
10"	3000
12"	4700
14"	5950
16"	9000
18"	13,500
20"	18,000
24"	32,000
30"	45,000
36"	69,000

NOTE: Recommended maximum flow rates may be reduced due to maximum velocity ratings. *C_v = the number of US gal/min that will result in 1 psi pressure loss across the valve at a temperature of 60° F.

INSTALLATION

The valve must be installed with the shaft in the vertical position for horizontal flow applications. The valve body is marked with a flow direction arrow and "TOP" to assist with proper positioning.

The torsion spring design allows valve plates to open and close with low pressures. Valves are not recommended on discharge of reciprocating compressors and pumps.



Tel: (410) 636-3380

Fax: (410) 789-1009

www.techno valve.com